

Power contactor, AC-3 400 A, 200 kW / 400 V AC (50-60 Hz) / DC operation 220-240 V UC Auxiliary contacts 2 NO + 2 NC 3-pole, Size S12 Busbar connections Drive: conventional screw terminal



Product brand name	SIRIUS
Product designation	Power contactor
Product type designation	3RT1
General technical data	
Size of contactor	S12
Product extension	
• function module for communication	No
• Auxiliary switch	Yes
Surge voltage resistance	
• of main circuit rated value	8 kV
• of auxiliary circuit rated value	6 kV
maximum permissible voltage for safe isolation	
• between coil and main contacts acc. to EN 60947-1	690 V
Protection class IP	
• on the front	IP00; IP20 on the front with cover / box terminal
• of the terminal	IP00
Shock resistance at rectangular impulse	
• at AC	8,5g / 5 ms, 4,2g / 10 ms

<ul style="list-style-type: none"> • at DC 	8,5g / 5 ms, 4,2g / 10 ms
Shock resistance with sine pulse	
<ul style="list-style-type: none"> • at AC 	13,4g / 5 ms, 6,5g / 10 ms
<ul style="list-style-type: none"> • at DC 	13,4g / 5 ms, 6,5g / 10 ms
Mechanical service life (switching cycles)	
<ul style="list-style-type: none"> • of contactor typical 	10 000 000
<ul style="list-style-type: none"> • of the contactor with added electronics-compatible auxiliary switch block typical 	5 000 000
<ul style="list-style-type: none"> • of the contactor with added auxiliary switch block typical 	10 000 000
Reference code acc. to DIN 40719 extended according to IEC 204-2 acc. to IEC 750	K
Reference code acc. to DIN EN 81346-2	Q

Ambient conditions

Installation altitude at height above sea level	
<ul style="list-style-type: none"> • maximum 	2 000 m
Ambient temperature	
<ul style="list-style-type: none"> • during operation 	-25 ... +60 °C
<ul style="list-style-type: none"> • during storage 	-55 ... +80 °C

Main circuit

Number of poles for main current circuit	3
Number of NO contacts for main contacts	3
Operating voltage	
<ul style="list-style-type: none"> • at AC-3 rated value maximum 	1 000 V
Operating current	
<ul style="list-style-type: none"> • at AC-1 at 400 V <ul style="list-style-type: none"> — at ambient temperature 40 °C rated value 	430 A
<ul style="list-style-type: none"> • at AC-1 <ul style="list-style-type: none"> — up to 690 V at ambient temperature 40 °C rated value 	430 A
<ul style="list-style-type: none"> — up to 690 V at ambient temperature 60 °C rated value 	400 A
<ul style="list-style-type: none"> — up to 1000 V at ambient temperature 40 °C rated value 	200 A
<ul style="list-style-type: none"> — up to 1000 V at ambient temperature 60 °C rated value 	200 A
<ul style="list-style-type: none"> • at AC-2 at 400 V rated value 	400 A
<ul style="list-style-type: none"> • at AC-3 <ul style="list-style-type: none"> — at 400 V rated value 	400 A
<ul style="list-style-type: none"> — at 500 V rated value 	400 A
<ul style="list-style-type: none"> — at 690 V rated value 	400 A
<ul style="list-style-type: none"> — at 1000 V rated value 	180 A

• at AC-4 at 400 V rated value	350 A
• at AC-5a up to 690 V rated value	378 A
• at AC-5b up to 400 V rated value	332 A
• at AC-6a	
— up to 230 V for current peak value n=20 rated value	377 A
— up to 400 V for current peak value n=20 rated value	377 A
— up to 500 V for current peak value n=20 rated value	377 A
— up to 690 V for current peak value n=20 rated value	377 A
— up to 1000 V for current peak value n=20 rated value	180 A
• at AC-6a	
— up to 230 V for current peak value n=30 rated value	251 A
— up to 400 V for current peak value n=30 rated value	251 A
— up to 500 V for current peak value n=30 rated value	251 A
— up to 690 V for current peak value n=30 rated value	251 A
— up to 1000 V for current peak value n=30 rated value	180 A
Minimum cross-section in main circuit	
• at maximum AC-1 rated value	300 mm ²
Operating current for approx. 200000 operating cycles at AC-4	
• at 400 V rated value	150 A
• at 690 V rated value	135 A
Operating current	
• at 1 current path at DC-1	
— at 24 V rated value	400 A
— at 110 V rated value	33 A
— at 220 V rated value	3.8 A
— at 440 V rated value	0.9 A
— at 600 V rated value	0.6 A
• with 2 current paths in series at DC-1	
— at 24 V rated value	400 A
— at 110 V rated value	400 A
— at 220 V rated value	400 A
— at 440 V rated value	4 A

— at 600 V rated value	2 A
• with 3 current paths in series at DC-1	
— at 24 V rated value	400 A
— at 110 V rated value	400 A
— at 220 V rated value	400 A
— at 440 V rated value	11 A
— at 600 V rated value	5.2 A
Operating current	
• at 1 current path at DC-3 at DC-5	
— at 24 V rated value	400 A
— at 110 V rated value	3 A
— at 220 V rated value	0.6 A
— at 440 V rated value	0.18 A
— at 600 V rated value	0.125 A
• with 2 current paths in series at DC-3 at DC-5	
— at 24 V rated value	400 A
— at 110 V rated value	400 A
— at 220 V rated value	2.5 A
— at 440 V rated value	0.65 A
— at 600 V rated value	0.37 A
• with 3 current paths in series at DC-3 at DC-5	
— at 24 V rated value	400 A
— at 110 V rated value	400 A
— at 220 V rated value	400 A
— at 440 V rated value	1.4 A
— at 600 V rated value	0.75 A
Operating power	
• at AC-1	
— at 230 V at 60 °C rated value	151 kW
— at 400 V rated value	263 kW
— at 400 V at 60 °C rated value	263 kW
— at 690 V rated value	454 kW
— at 690 V at 60 °C rated value	454 kW
— at 1000 V at 60 °C rated value	329 kW
• at AC-2 at 400 V rated value	200 kW
• at AC-3	
— at 230 V rated value	132 kW
— at 400 V rated value	200 kW
— at 500 V rated value	250 kW
— at 690 V rated value	400 kW
— at 1000 V rated value	250 kW

Operating power for approx. 200000 operating cycles at AC-4	
<ul style="list-style-type: none"> • at 400 V rated value • at 690 V rated value 	<p>85 kW</p> <p>133 kW</p>
Thermal short-time current limited to 10 s	3 200 A
Power loss [W] at AC-3 at 400 V for rated value of the operating current per conductor	35 W
No-load switching frequency	
<ul style="list-style-type: none"> • at AC • at DC 	<p>2 000 1/h</p> <p>2 000 1/h</p>
Operating frequency	
<ul style="list-style-type: none"> • at AC-1 maximum • at AC-2 maximum • at AC-3 maximum • at AC-4 maximum 	<p>700 1/h</p> <p>200 1/h</p> <p>500 1/h</p> <p>130 1/h</p>

Control circuit/ Control	
Type of voltage of the control supply voltage	AC/DC
Control supply voltage at AC	
<ul style="list-style-type: none"> • at 50 Hz rated value • at 60 Hz rated value 	<p>220 ... 240 V</p> <p>220 ... 240 V</p>
Control supply voltage at DC	
<ul style="list-style-type: none"> • rated value 	220 ... 240 V
Operating range factor control supply voltage rated value of magnet coil at DC	
<ul style="list-style-type: none"> • initial value • Full-scale value 	<p>0.8</p> <p>1.1</p>
Operating range factor control supply voltage rated value of magnet coil at AC	
<ul style="list-style-type: none"> • at 50 Hz • at 60 Hz 	<p>0.8 ... 1.1</p> <p>0.8 ... 1.1</p>
Design of the surge suppressor	with varistor
Apparent pick-up power of magnet coil at AC	
<ul style="list-style-type: none"> • at 50 Hz 	830 V·A
Inductive power factor with closing power of the coil	
<ul style="list-style-type: none"> • at 50 Hz 	0.9
Apparent holding power of magnet coil at AC	
<ul style="list-style-type: none"> • at 50 Hz 	9.2 V·A
Inductive power factor with the holding power of the coil	
<ul style="list-style-type: none"> • at 50 Hz 	0.9
Closing power of magnet coil at DC	920 W
Holding power of magnet coil at DC	10 W
Closing delay	

<ul style="list-style-type: none"> • at AC • at DC 	<p>45 ... 100 ms</p> <p>45 ... 100 ms</p>
Opening delay <ul style="list-style-type: none"> • at AC • at DC 	<p>60 ... 100 ms</p> <p>60 ... 100 ms</p>
Arcing time	10 ... 15 ms
Control version of the switch operating mechanism	Standard A1 - A2

Auxiliary circuit

Number of NC contacts for auxiliary contacts <ul style="list-style-type: none"> • instantaneous contact 	2
Number of NO contacts for auxiliary contacts <ul style="list-style-type: none"> • instantaneous contact 	2
Operating current at AC-12 maximum	10 A
Operating current at AC-15 <ul style="list-style-type: none"> • at 230 V rated value • at 400 V rated value • at 500 V rated value • at 690 V rated value 	<p>6 A</p> <p>3 A</p> <p>2 A</p> <p>1 A</p>
Operating current at DC-12 <ul style="list-style-type: none"> • at 24 V rated value • at 48 V rated value • at 60 V rated value • at 110 V rated value • at 125 V rated value • at 220 V rated value • at 600 V rated value 	<p>10 A</p> <p>6 A</p> <p>6 A</p> <p>3 A</p> <p>2 A</p> <p>1 A</p> <p>0.15 A</p>
Operating current at DC-13 <ul style="list-style-type: none"> • at 24 V rated value • at 48 V rated value • at 60 V rated value • at 110 V rated value • at 125 V rated value • at 220 V rated value • at 600 V rated value 	<p>10 A</p> <p>2 A</p> <p>2 A</p> <p>1 A</p> <p>0.9 A</p> <p>0.3 A</p> <p>0.1 A</p>
Contact reliability of auxiliary contacts	1 faulty switching per 100 million (17 V, 1 mA)

UL/CSA ratings

Full-load current (FLA) for three-phase AC motor <ul style="list-style-type: none"> • at 480 V rated value • at 600 V rated value 	<p>361 A</p> <p>382 A</p>
Yielded mechanical performance [hp] <ul style="list-style-type: none"> • for three-phase AC motor 	

— at 200/208 V rated value	125 hp
— at 220/230 V rated value	150 hp
— at 460/480 V rated value	300 hp
— at 575/600 V rated value	400 hp

Contact rating of auxiliary contacts according to UL A600 / Q600

Short-circuit protection

Design of the fuse link

<ul style="list-style-type: none"> • for short-circuit protection of the main circuit <ul style="list-style-type: none"> — with type of coordination 1 required — with type of assignment 2 required • for short-circuit protection of the auxiliary switch required 	<p>gG: 630 A (690 V, 100 kA)</p> <p>gG: 500 A (690 V, 100 kA), aM: 400 A (690 V, 50 kA), BS88: 450 A (415 V, 50 kA)</p> <p>gG: 10 A (500 V, 1 kA)</p>
---	---

Installation/ mounting/ dimensions

Mounting position with vertical mounting surface +/-90° rotatable, with vertical mounting surface +/- 22.5° tiltable to the front and back

Mounting type screw fixing

• Side-by-side mounting Yes

Height 214 mm

Width 160 mm

Depth 225 mm

Required spacing

<ul style="list-style-type: none"> • with side-by-side mounting <ul style="list-style-type: none"> — forwards 20 mm — upwards 10 mm — downwards 10 mm — at the side 0 mm • for grounded parts <ul style="list-style-type: none"> — forwards 20 mm — upwards 10 mm — at the side 10 mm — downwards 10 mm • for live parts <ul style="list-style-type: none"> — forwards 20 mm — upwards 10 mm — downwards 10 mm — at the side 10 mm 	
--	--

Connections/ Terminals

Type of electrical connection

• for main current circuit	Connection bar
• for auxiliary and control current circuit	screw-type terminals

<ul style="list-style-type: none"> • at contactor for auxiliary contacts • of magnet coil 	<p>Screw-type terminals</p> <p>Screw-type terminals</p>
Type of connectable conductor cross-sections <ul style="list-style-type: none"> • at AWG conductors for main contacts 	2/0 ... 500 kcmil
Connectable conductor cross-section for main contacts <ul style="list-style-type: none"> • stranded 	70 ... 240 mm ²
Connectable conductor cross-section for auxiliary contacts <ul style="list-style-type: none"> • single or multi-stranded • finely stranded with core end processing 	<p>0.5 ... 4 mm²</p> <p>0.5 ... 2.5 mm²</p>
Type of connectable conductor cross-sections <ul style="list-style-type: none"> • for auxiliary contacts <ul style="list-style-type: none"> — solid — single or multi-stranded — finely stranded with core end processing • at AWG conductors for auxiliary contacts 	<p>2x (0.5 ... 1.5 mm²), 2x (0.75 ... 2.5 mm²), max. 2x (0.75 ... 4 mm²)</p> <p>2x (0,5 ... 1,5 mm²), 2x (0,75 ... 2,5 mm²), max. 2x (0,75 ... 4 mm²)</p> <p>2x (0.5 ... 1.5 mm²), 2x (0.75 ... 2.5 mm²)</p> <p>2x (20 ... 16), 2x (18 ... 14), 1x 12</p>
AWG number as coded connectable conductor cross section <ul style="list-style-type: none"> • for auxiliary contacts 	18 ... 14

Safety related data

B10 value <ul style="list-style-type: none"> • with high demand rate acc. to SN 31920 	1 000 000
Product function <ul style="list-style-type: none"> • Mirror contact acc. to IEC 60947-4-1 • positively driven operation acc. to IEC 60947-5-1 	<p>Yes</p> <p>No</p>
Protection against electrical shock	finger-safe when touched vertically from front acc. to IEC 60529

Certificates/ approvals

General Product Approval	Functional Safety/Safety of Machinery	Declaration of Conformity
--------------------------	---------------------------------------	---------------------------



[Type Examination Certificate](#)



Declaration of Conformity	Test Certificates	Marine / Shipping
---------------------------	-------------------	-------------------

[Miscellaneous](#)

[Special Test Certificate](#)

[Type Test Certificates/Test Report](#)

[Miscellaneous](#)



Marine / Shipping	other	Railway
-------------------	-------	---------



[Miscellaneous](#)

[Confirmation](#)

[Special Test Certificate](#)

Further information

Information- and Downloadcenter (Catalogs, Brochures,...)

www.siemens.com/sirius/catalogs

Industry Mall (Online ordering system)

<https://mall.industry.siemens.com/mall/en/en/Catalog/product?mlfb=3RT1075-6AP36>

Cax online generator

<http://support.automation.siemens.com/WW/CAXorder/default.aspx?lang=en&mlfb=3RT1075-6AP36>

Service&Support (Manuals, Certificates, Characteristics, FAQs,...)

<https://support.industry.siemens.com/cs/ww/en/ps/3RT1075-6AP36>

Image database (product images, 2D dimension drawings, 3D models, device circuit diagrams, EPLAN macros, ...)

http://www.automation.siemens.com/bilddb/cax_de.aspx?mlfb=3RT1075-6AP36&lang=en

Characteristic: Tripping characteristics, I²t, Let-through current

<https://support.industry.siemens.com/cs/ww/en/ps/3RT1075-6AP36/char>

Further characteristics (e.g. electrical endurance, switching frequency)

<http://www.automation.siemens.com/bilddb/index.aspx?view=Search&mlfb=3RT1075-6AP36&objecttype=14&gridview=view1>

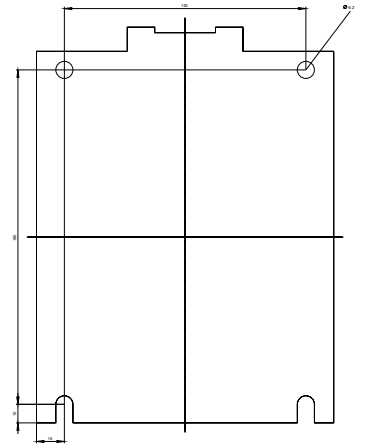
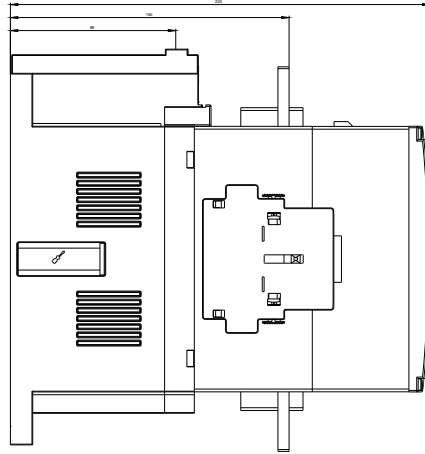
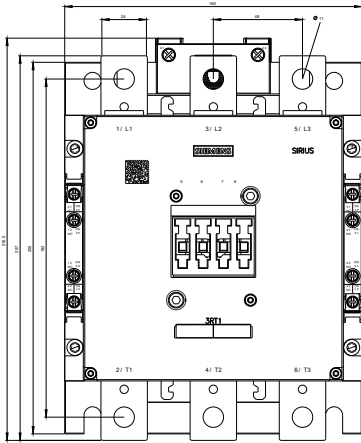

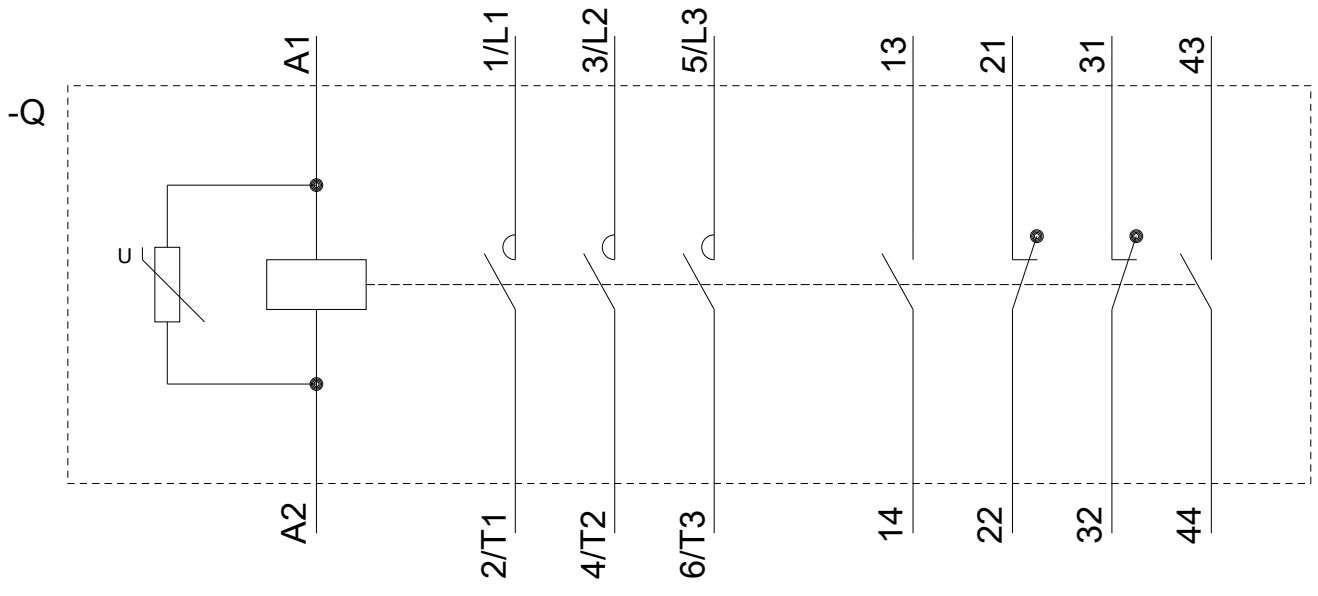

last modified:

08/01/2019